



SECO/WARWICK



Controlled Atmosphere Aluminum Brazing Systems

www.secowarwick.com.pl

Aluminum Brazing

SECO/WARWICK is one of the world's most experienced and innovative furnace manufacturers with over 200 CAB Brazing Systems installed worldwide.

Our commitment to quality products begins in engineering and continues through the complete installation of your system, including aftermarket support. ISO 9001 certification in our global manufacturing facilities ensures our high-quality standards are adhered to throughout the manufacturing process.

Controlled atmosphere brazing of aluminum (CAB), using a noncorrosive flux, is the preferred process for manufacturing **aluminum heat exchangers**. Since entering this field in 1983, SECO/WARWICK has led the development of advanced technology in the continuous flow brazing process. Capitalizing on over 100 years of furnace design experience, SECO/WARWICK has driven innovations such as:

- Improved muffle design
- Convection heating technology
- Continuous atmosphere control systems
- ACCUBRAZE® PC/PLC controls
- Prioritized heating control systems including sinuous loop and gas fired systems
- Energy saving designs
- System rebuilds and upgrades
- Feasibility studies

So far the main CAB equipment's customers were the representative of **the automotive industry**. Now the **HVACR - (Heating, Ventilation, Air-Conditioning, Refrigeration)** industry is the rising, promising market for a CAB process.

These innovations, along with others, have led to the design of a variety of brazing furnace systems to meet the growing demand for aluminum brazing. Each of these systems provides unique benefits based on the size and scope of a manufacturer's individual brazing needs. Custom engineered solutions range from small batch vacuum purge brazing systems and semi-continuous systems for infrequent demand, to large scale continuous based furnace systems designed to deliver efficient, flexible throughput on a continuous basis. SECO/WARWICK will complete the offering with all the support services necessary to ensure a smooth start-up of your new system.

CAB Process Advantages

The controlled atmosphere brazing (CAB) process heats a product to brazing temperatures while maintaining uniform temperatures within the product in an oxygen-free nitrogen atmosphere. During furnace brazing, a brazing sheet (fig. 1) of aluminum/silicon alloy plate (cladding) is heated to a liquid state and flows to form aluminum joints or fillets. A sample of a fillet is shown in figure 2. Figure 3 shows an Al - Si phase diagram giving reference to the different alloys used for CAB brazing with temperatures of the liquid phase for each. (Note: AVB is aluminum vacuum brazing).



Index	Page
Aluminum Brazing	2
CAB process advantages	3
The CAB process	4-5
Radiation CAB Furnace	6
Convection / Radiation CAB Furnace	7
Convection CAB Furnace	8
Active Only® Convection CAB Furnace	9
Vertical Brazing CAB Furnace	10
Vacuum Purge CAB Furnace	10
Aftermarket Services	11

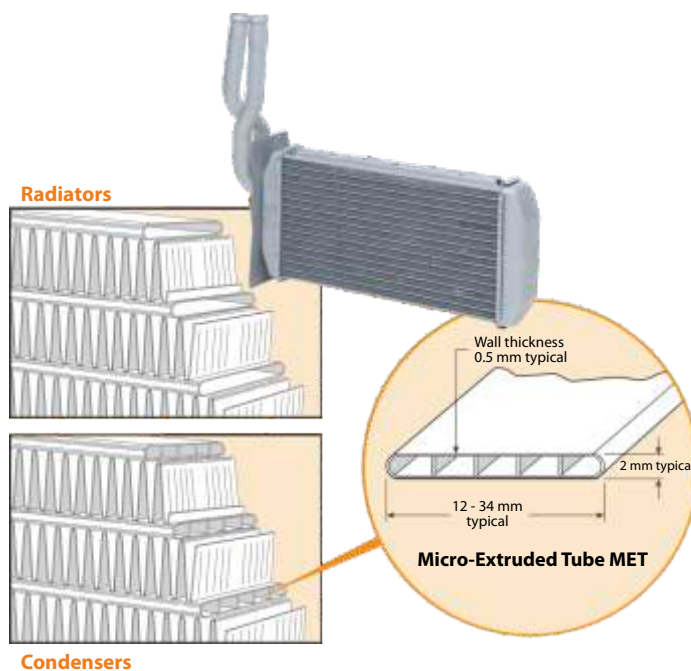

Controlled Atmosphere Aluminum Brazing Systems

Controlled atmosphere brazing's advantages include:

- Accepts a less demanding dimensional fit-up
- Flux is noncorrosive, requiring no post braze cleaning
- Less capital intensive compared to vacuum brazing
- Continuous flow for high volume throughput

Although heat exchangers such as radiators, condensers, oil coolers, evaporators, heaters, and charge air coolers for the automotive industry dominate current demand, other applications continue to lend themselves to aluminum brazing. Consumer applications for air conditioners and various appliances will benefit from this process. Other emerging innovations with unclad braze sheet, micro-extrusion technology, and combination heat exchangers ensure the continuation of the CAB process far into the next decade. The future is bright for smart investment in technology that is positioned for strong growth.

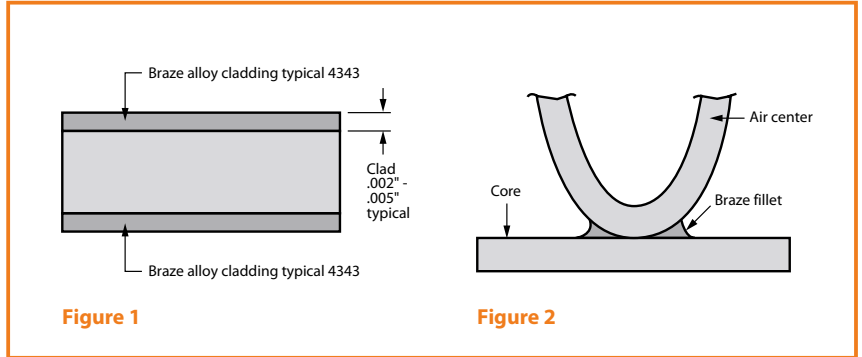
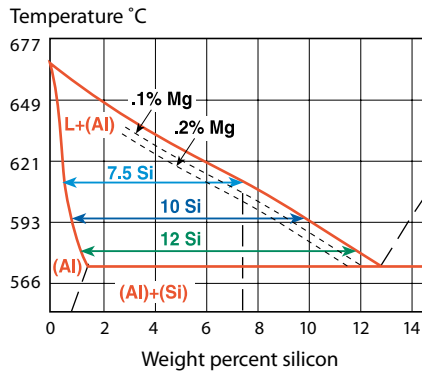

Figure 1

Figure 2

Al - Si Phase Diagram

Figure 3



Alloy Melt Range °C

1350 Liner	646 - 657
3003 CAB Core	643 - 654
3005 AVB Core	638 - 657
6061 Fittings	638 - 652
4343 CAB & AVB Clad	577 - 612
4045 CAB & AVB Clad	577 - 599
4047 CAB & AVB Clad	577 - 582

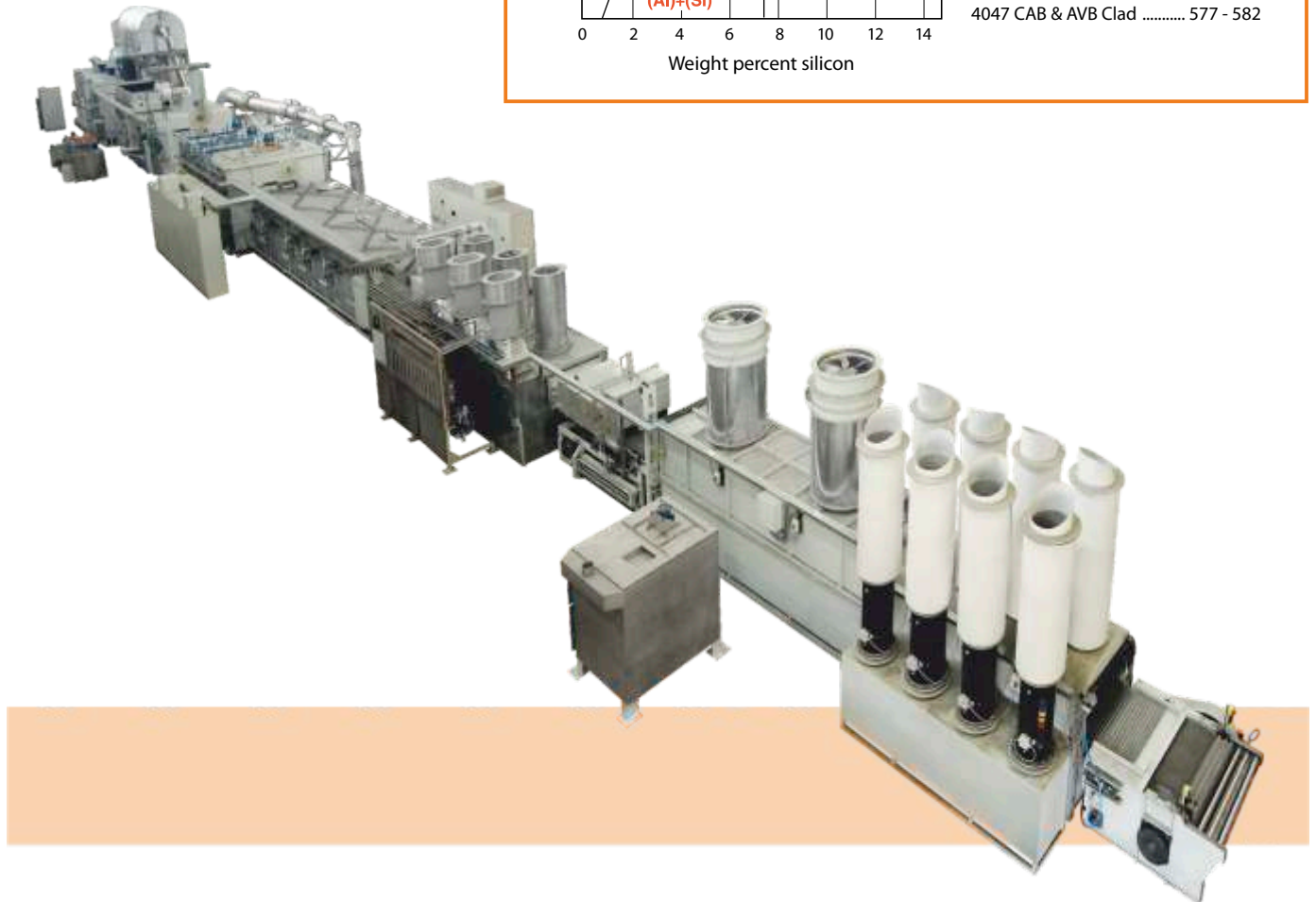

Controlled Atmosphere Brazing Process

A fully configured CAB furnace system includes an aqueous washer or thermal degreaser, a fluxer unit, a dry off oven, and the CAB furnace. These systems can be configured in an in-line, a continuous rectangular line, or a U-shaped line to meet your plant's installation space requirements.



Thermal Degreaser

Thermal Degreaser

A Thermal Degreaser Oven will thermally remove the lubricating oils present on the heat exchanger from prior fabrication stages. The assembled and fixtured product will be placed on the oven conveyor for processing. The oven will typically operate at 250 – 300°C to vaporize the oils. If light evaporative oils are used in the process, the vapors from the products are oxidized in the combustion chamber. If heavier lubricating oils are used, an incinerator at the oven exhaust may be required. The products must then be cooled back to ambient temperature prior to the fluxing process.



Thermal Incinerator

Incinerators

Thermal degreaser ovens are usually equipped with the equipment for reducing the VOC emission to the legal limits. The standard solution for this process is the thermal incinerator where the oil vapor is burned in high temperature. The thermal incinerator is usually installed with a kind of heat recovery system to reduce the energy consumption.

The new solution for reducing the VOC emission is the process based on using the catalytic bed. Although high investing cost the very low energy consumption makes this solution more profitable.

Continuous operating CAB furnace with five preheat and seven braze zones



Controlled Atmosphere Aluminum Brazing Systems

Flux Application

SECO/WARWICK's continuous flow two-station fluxer is built on a rugged steel channel frame and surrounded by stainless steel plate.

The flux applicator is the latest in design to apply the flux mixture directly to the body part or header as your specifications require. Once applied, a series of adjustable, powerful air knives, positioned over and to the sides of the conveyor, strip away the excess flux from the part.

The complete system includes necessary pumps, strainers, inlet and outlet pressure gauges, adjustable discharge spray manifold headers and nozzles, two portable stainless steel flux totes with agitators, a recirculated flux blow-off complete with air knife, a mist eliminator and exhaust fan, a variable speed conveyor drive, and all the necessary piping to make a single connection complete with valves. The unit has a pre-wired control cabinet complete with main disconnect switch interlocked with the door for safety.

Products requiring internal fluxing will require special consideration depending on the heat exchanger design.



Fluxer



Dry Off Oven

Dry Off Oven

The dry off oven is the final preparation before brazing.

Our ovens are built of an aluminized steel exterior shell and a stainless steel internal skin filled with industrial insulation. The oven's internal components are constructed of stainless steel to ensure a long working life. Heat is provided by electric, propane, or a natural gas fuel source.

The parts are conveyed into the oven, where they are heated and dried prior to brazing. The air is heated in an air supply chamber and then forced up through the work. The hot air is collected at the top of the oven and recirculated back to the heat source for use in the oven again. All duct work and fans are constructed of stainless steel. The oven temperature, over temperature control, and all pertinent machine controls are mounted in the system control panel.



CAB Brazing Furnace System

CAB Furnaces

The controlled atmosphere brazing process uses a noncorrosive flux to reduce the tenacious aluminum oxide over layer that forms on the heat exchanger aluminum surface. SECO/WARWICK CAB furnaces provide the pure nitrogen atmosphere and temperature profile necessary to promote the formation of braze fillets between the fin and tubes and the tube to header joints of aluminum heat exchangers.

The following furnace designs are available to produce a variety of parts in large or small volume production runs:

- Radiation CAB furnace
- Convection/Radiation CAB furnace
- Convection CAB furnace
- Active Only® CAB furnace
- Vacuum purge furnace

These brazing furnace systems are covered in detail in the following pages. Whether you need a small quantity of prototype parts or your business demands high volume production of various sizes and types of aluminum parts, SECO/WARWICK will custom engineer your controlled atmosphere brazing furnace system.

Radiation CAB Furnace

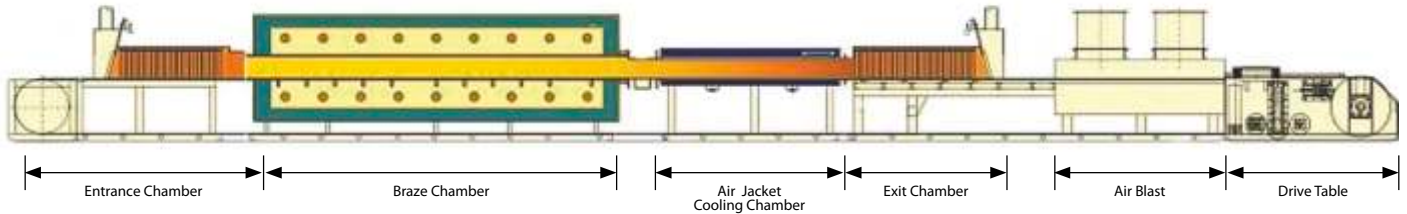

A radiation braze CAB furnace is an ideal method for brazing similar size products in a continuous flow environment. If you intend to produce a single or only a few variations of that product, a radiation furnace system makes sense.

This furnace is designed to use a heated muffle to braze the product. Our design includes proportionally controlled electric heating elements to heat the muffle, which in turn provides the radiant heat to the products. Natural gas fired combustion systems are available as an option. Temperatures are controlled uniformly throughout the length of the furnace by several independently heated zones.

Muffle design is quite important to the overall efficiency of the system. SECO/WARWICK manufactures its muffles with the high level of craftsmanship the process demands. Radiation CAB furnaces are very efficient with respect to the consumption of the nitrogen atmosphere and require less maintenance compared to the other CAB methods.

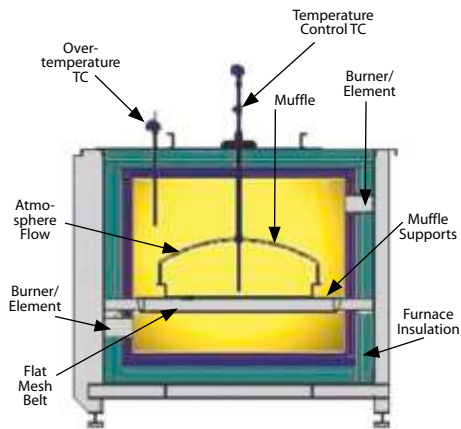

Radiation Brazing Chamber Cross-Section

Furnace type	Radiation braze	Convection preheat / radiation braze	Convection braze
Time to braze	High	Medium	Low
Product intermixing	Low	Medium	High
Temperature uniformity	Medium	Medium/High	High
Atmosphere consumption	Low	Low	Medium
Required maintenance	Low	Low	Medium
Brazing efficiency	Medium	Medium/High	High
Flexibility	Low	Medium	High
Cost	Low	Medium	High

Profile

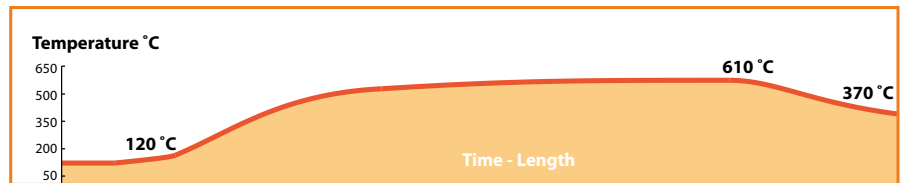

Controlled Atmosphere Aluminum Brazing Systems

Convection / Radiation CAB Furnace

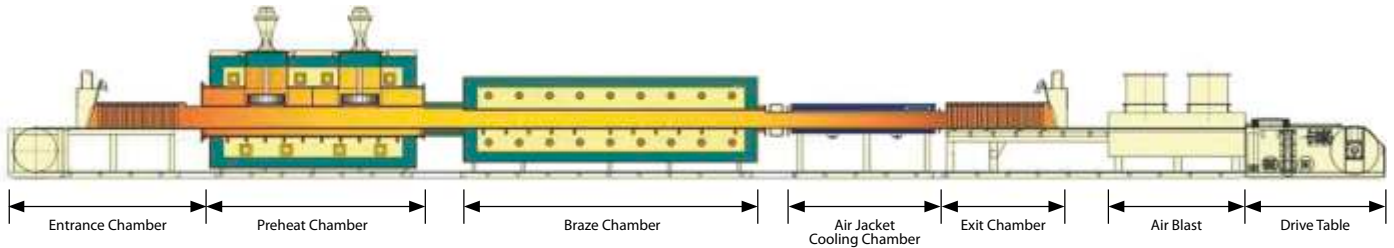

When your brazing needs are more diverse, a combination convection preheating and radiation brazing furnace system could be your answer. The addition of convection preheating improves the furnace's overall flexibility, enabling manufacturers to run product of different mass and dimension in the same cycle. This type of system is more forgiving when running production intermittently.

The initial heat zone, in the above graphic, uses both convection and radiation heat to uniformly preheat an assortment of products. Once preheated, the product moves into the radiation brazing section, where the product is brought to and held at a uniform temperature to allow the clad materials to melt and form a joint.

All of our continuous CAB furnaces use a variable speed drive and a stainless steel mesh belt to move product.

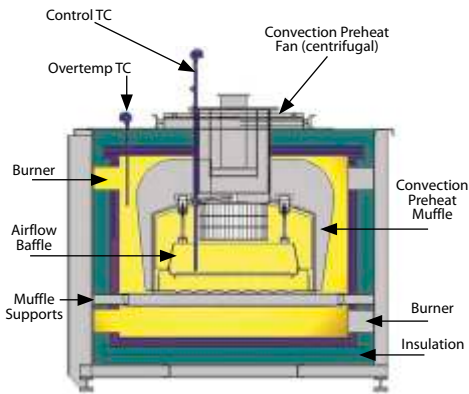

Preheat Section

Furnace type	Radiation braze	Convection preheat / radiation braze	Convection braze
Time to braze	High	Medium	Low
Product intermixing	Low	Medium	High
Temperature uniformity	Medium	Medium/High	High
Atmosphere consumption	Low	Low	Medium
Required maintenance	Low	Low	Medium
Brazing efficiency	Medium	Medium/High	High
Flexibility	Low	Medium	High
Cost	Low	Medium	High

Profile

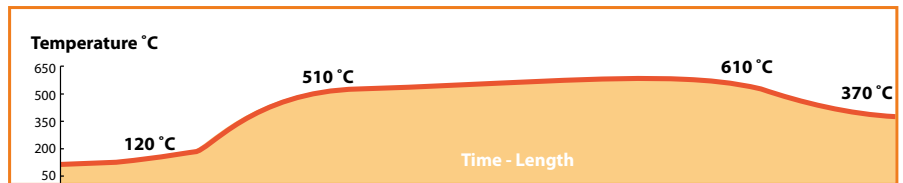

Convection CAB Furnace

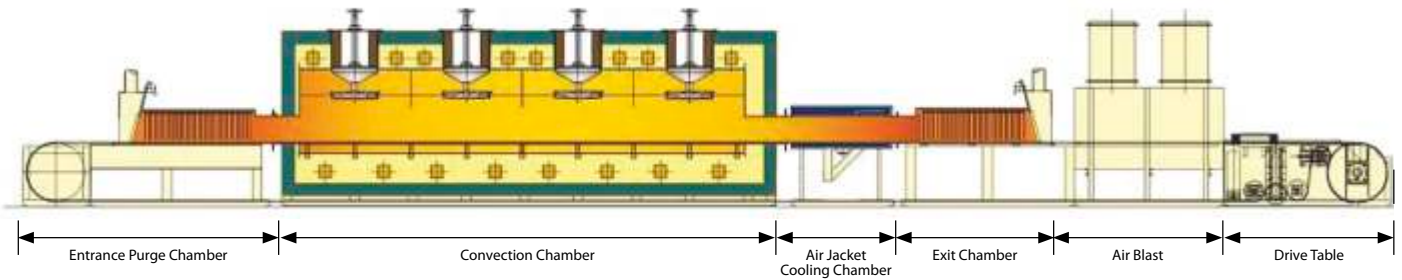

A pure convection heat controlled atmosphere furnace system is the most efficient means to braze a wide variety of products in the shortest possible cycle time. Product throughput is the name of the game here.

SECO/WARWICK convection furnaces maintain excellent temperature uniformity to within ± 3 degrees C. Convection heat transfer is used to bring the entire part to brazing temperature in a recirculated nitrogen atmosphere.

A convection system takes less floor space due to its shorter overall length when considering furnaces of similar production throughput. Cycle heating times can be as low as 5 minutes, while mixing loads with diverse products. These furnace systems are popular in the automotive industry where installation space requirements are at a premium and intermixing of various size products is the norm. Convection systems show great promise in emerging applications, making them a solid investment for the future. A convection CAB furnace is the most efficient means to braze large heat exchangers used in the heavy duty and off-road industry.

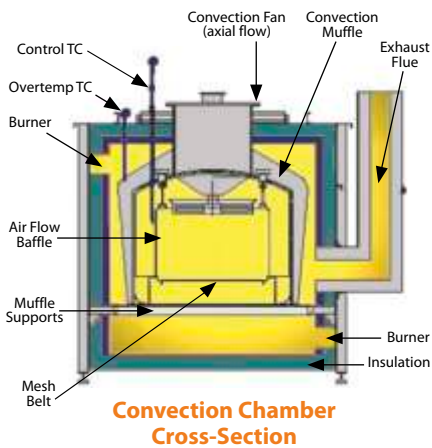

Furnace type	Radiation braze	Convection preheat / radiation braze	Convection braze
Time to braze	High	Medium	Low
Product intermixing	Low	Medium	High
Temperature uniformity	Medium	Medium/High	High
Atmosphere consumption	Low	Low	Medium
Required maintenance	Low	Low	Medium
Brazing efficiency	Medium	Medium/High	High
Flexibility	Low	Medium	High
Cost	Low	Medium	High

Profile

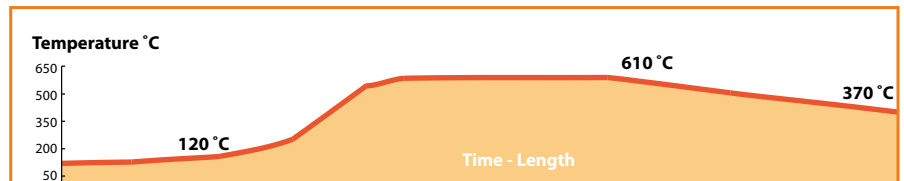

Controlled Atmosphere Aluminum Brazing Systems

Active Only® Convection CAB Furnace

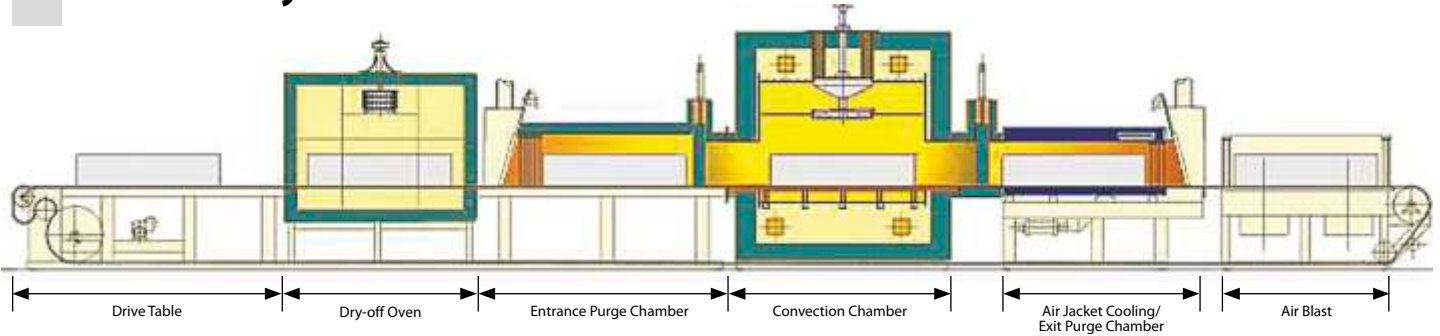

The Active Only® furnace system is designed to operate on a part-time basis. The furnace can be brought up to brazing temperature from ambient and conditioned with a proper atmosphere in a very short time. This semi-continuous system allows for variable heating and cooling rates, depending on indexing times. This furnace can braze the widest variety of heat exchangers with lower production requirements.

Our Active Only® furnace is based on a six step indexing cycle. The six indexing positions include the load table position, the dry off oven, the entrance purge chamber, the patented convection brazing chamber, the air jacketed cooling/exit purge chamber and the airblast chamber. The product runs in a horizontal position with an infinitely adjustable dwell time based on the hearth load and load configuration. A thermocoupled work zone monitors recovery time when the load is run intermittently.

This system includes innovative features to improve brazing efficiency. The furnace ensures a uniform preheat of product through a patented muffle configuration. It maintains a low consumption of the nitrogen atmosphere, is electrically or gas efficient, and is completely computer controlled.

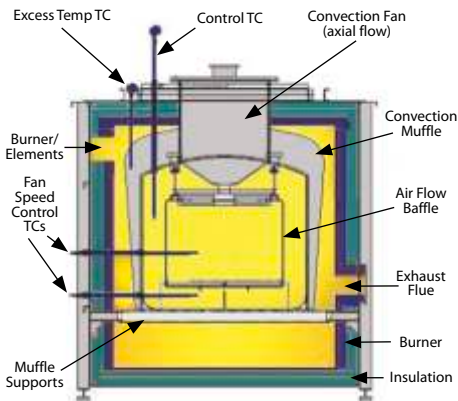

Brazing Chamber

The cycle time for various loads controlled automatically by accubraise system. Similar temperature profile around brazing phase

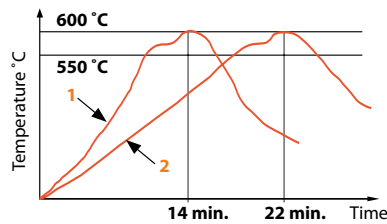

1. Light-weight heat exchanger.
2. Heavy-duty heat exchanger.



Convection heating with accurate temperature control and uniformity are essential when running loads with varying masses and configurations. The ACTIVE ONLY® furnace is controlled by a PC/PLC based system utilizing ACCUBRAZE® software to compensate automatically for the different load sizes.



Vertical Brazing CAB Furnace



A uniquely designed version of an "Active Only"[®] indexing furnace has been developed, where the brazed elements are positioned horizontally. For some types of heat exchangers such orientation provides benefits as the cladding melts. Vertical positioning of the heat exchanger allows the joints to be evenly filled on a horizontal plane. This prevents the brazing alloy from accumulating on one side of the heat exchanger. Additionally, the furnaces that are utilizing the vertical brazing position are also using a vacuum purge. This solution has limited the nitrogen consumption and has definitely improved furnace atmosphere cleanliness. Due to vacuum flushing in the furnace vestibule, air is removed not only in the chamber but also from the internal openings of the heat exchanger. Furnaces of this type may be used in the production of some types of heat exchangers, which previously required a more expensive technology of brazing in vacuum furnaces.

Vacuum Purge CAB Furnace

For low volume brazing production or prototyping

The vacuum purge batch CAB furnace is an advanced hot wall, front loading retort furnace with vacuum purging especially designed for aluminum brazing. The standard furnace hot zone is 600 mm x 600 mm x 900 mm (24" x 24" x 36"), however SECO/WARWICK can custom engineer furnaces to suit the application.

This furnace has a compact design with an internal recirculation fan and external cooling air blower. The packaged furnace system consists of the heating system, vacuum pumping system, nitrogen system and atmosphere controls. The brazing cycle begins with vacuum purging of the stainless steel retort with N₂ backpurge, followed by fast and uniform heating up to brazing temperature. When the soak cycle is complete, the cooling cycle is initiated.

The advantage of a vacuum purge batch furnace is that it is always ready for

work at room temperature and it is cold when the cycle is completed. No pre-heating is required.

For highly sophisticated R & D requirements, a special version vacuum purge CAB furnace is available. This special design enables precise control of the heating and cooling speeds during the entire cycle. Atmosphere conditions like oxygen and/or dewpoint can be set on the defined level. This batch type furnace allows the user to simulate a wide range of brazing conditions that would be experienced in a continuous furnace.



Controlled Atmosphere Aluminum Brazing Systems

SECO/WARWICK's Worldwide Aftermarket Parts and Service

SECO/WARWICK can provide field technical support and replacement parts for all equipment manufactured by both SECO/WARWICK and Camlaw Ltd. (SECO/WARWICK is the exclusive supplier of CAMLAW CAB equipment service and replacement parts). We have successfully provided both parts and rebuild services for other manufacturers as well. Technicians are available for equipment breakdowns, rebuilds, upgrades, relocating equipment, trouble shooting, and preventative maintenance. SECO/WARWICK specializes in providing furnace parts of all types including heating elements, sinuous loop heating elements, fan assemblies, thermocouples, muffles, mesh belts and short cycle fabrications.



Aftermarket images:

- 1. Sinuous Loop Heating Elements
- 2. Convection Muffle US Patent #5,271,545
- 3. Radiation Muffle
- 4. Mesh Belt Replacement
- 5. Furnace Curtain





SECO/WARWICK Group

POLAND

SECO/WARWICK S.A.
ul. Sobieskiego 8
66-200 Świebodzin
Tel: +48 68 3820 501
Fax: +48 68 3820 555
info@secowarwick.com.pl
www.secowarwick.com.pl

USA

SECO/WARWICK Corp.
P.O. Box 908, 180 Mercer St.
Meadville, PA 16335-6908
Tel: +1 814 332 8400
Fax: +1 814 724 1407
info@secowarwick.com
www.secowarwick.com

USA

RETECH SYSTEMS LLC
100 Henry Station Rd.
Ukiah, CA 95482, USA
Tel: +1 707 462 6522
Fax: +1 707 462 4103
jferriau@retechsystemsllc.com
www.retechsystemsllc.com

GERMANY

SECO/WARWICK GmbH
Heilbronner Strasse 150
70191 Stuttgart, Germany
Tel: +49 711 217 29 60 10
Fax: +49 711 217 29 60 19
info@secowarwick.de
www.secowarwick.de

POLAND

SECO/WARWICK Thermal S.A.
(formerly Elterma)
ul. Świerczewskiego 76
66-200 Świebodzin
Tel: +48 68 3819 800
Fax: +48 68 3819 805
thermal@secowarwick.com.pl
www.secowarwickthermal.com.pl

INDIA

SECO/WARWICK Allied Pvt. Ltd.
Allied House, Road No.1,
Chembur, Mumbai n̄ 400 071, India
Tel: +91 22 2528 4028
+91 22 6797 3018
Fax: +91 22 2554 8782
ACEPL - allied@alliedfurnaces.com
AF - incinerator@alliedfurnaces.com
www.alliedfurnaces.com

CHINA

SECO/WARWICK RETECH
Thermal Equipment Manufacturing
(Tianjin) Co., Ltd.
7B Second Xeda Road
Tianjin, China 300385
Tel: +86 22 238 28300
Fax: +86 22 238 28305
s.wozniak@secowarwick.com.pl
www.swretech.com.cn

RUSSIA

SECO/WARWICK
Kostyakova 11/1
125422 Moscow, Russia
Tel/Fax: +7 495 9767160
Tel/Fax: +7 495 9777435
moscow@secowarwick.com.pl
www.secowarwick.com.pl